

THE BOWL

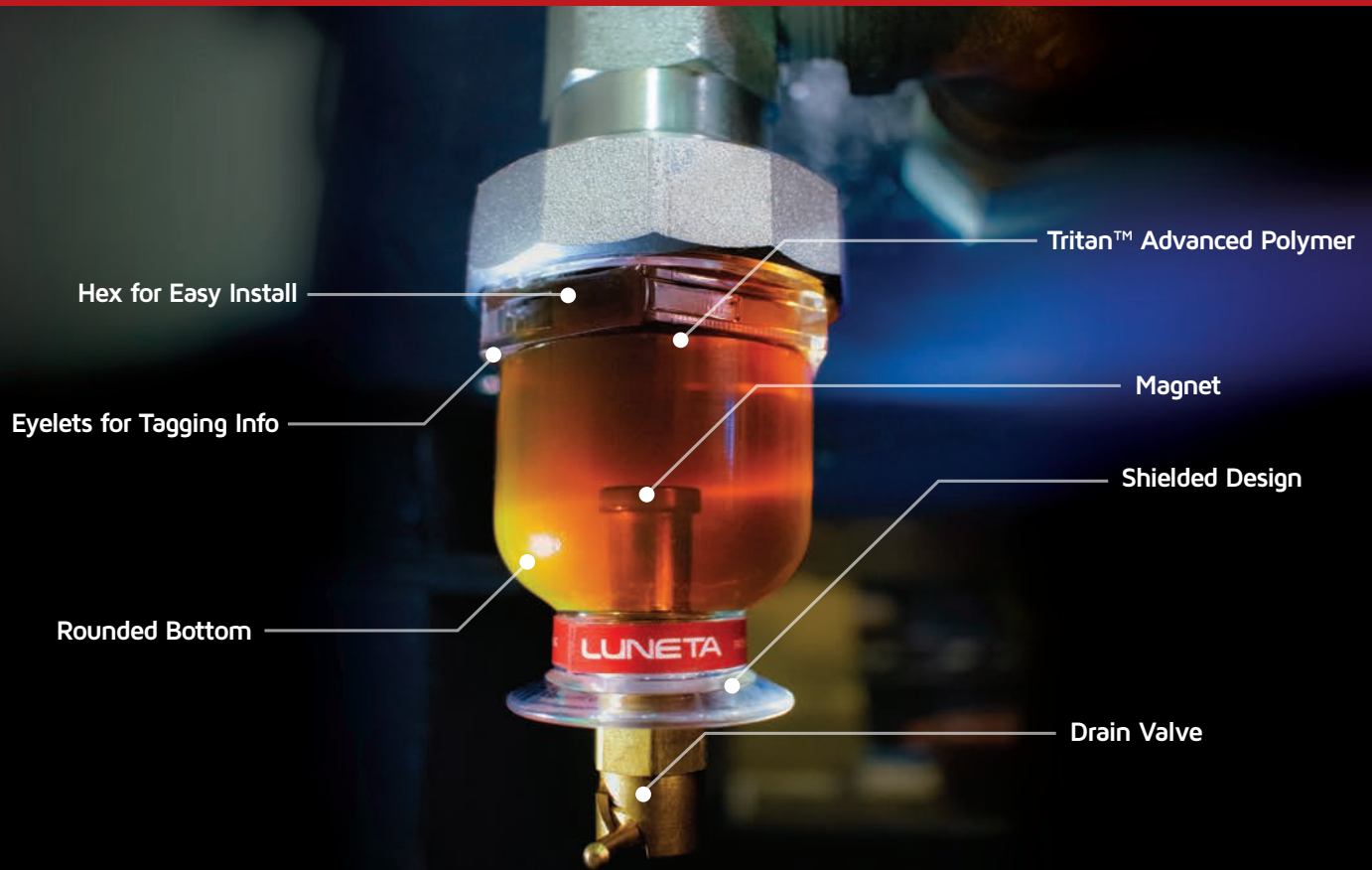

The Bowl is a patent-pending 3D sight glass created specifically for the drain port.

The Bowl is designed to both condition monitor and to trap and purge bottom sediment and water. The rounded bottom and accompanying drain valve efficiently captures and purges both water and sediment that gravity pulls to the bottom. A built-in magnet captures and displays ferrous wear debris. A shield protects the outside of the valve from accumulating debris and impacts. Like other Luneta products, the Bowl provides a nearly 360° view of the oil thanks to the ultra-durable, crystal-clear and chemically resistant Tritan™ material. A built-in hex makes installation easy with a socket wrench or pliers. Two eyelets are provided for tagging useful information such as oil type and an oil color change card. And all of these features are packed into a single molded piece to eliminate leak points.



Sludge Pump - Using Bowl to Purge Water and Sediment



Large Blower - Wastewater Treatment Plant



Clarifier - Wastewater Treatment Plant

Available Male Thread Size:
NPT 3/8", 1/2", 3/4", 1" and 1-1/2"

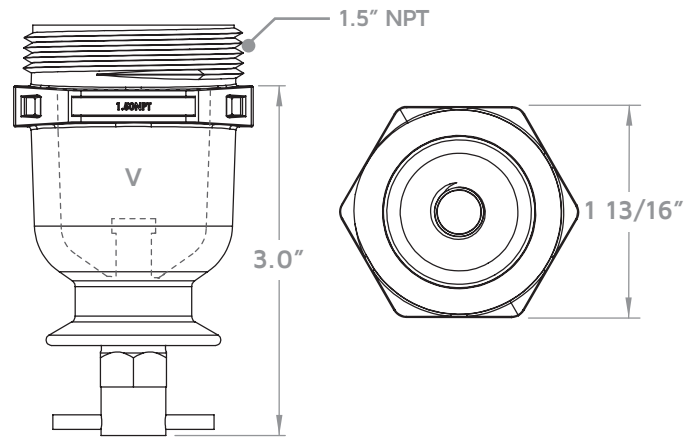
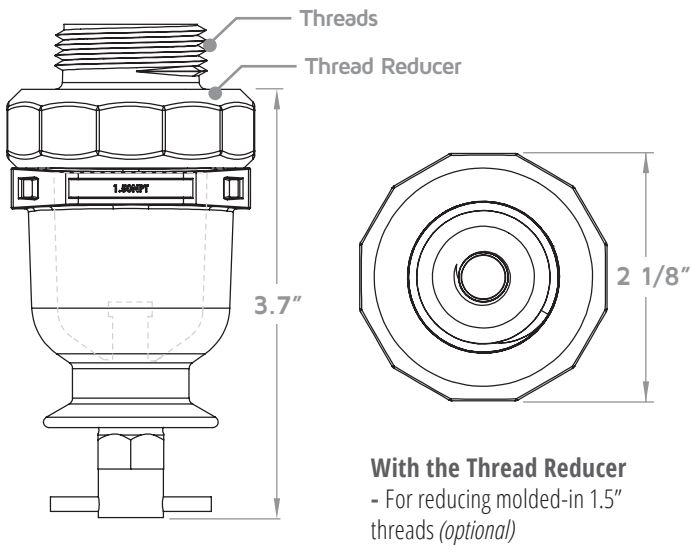

V - Volume

SPECIFICATIONS
<ul style="list-style-type: none"> • Application: Drain ports • Volume: 1.0 fl.oz. • Threads: Varies (see table) • Dimensions: (see graphic) • Shipping Weight: 12 oz. each • Recommended Temperature: -40°F to 200°F (-40°C to 93°C) • Recommended Pressure: 65 psi./4.5 bar • Sampling/Drain Valves: Drain valve, spiral to open, turn to lock • Materials: Bowl: Tritan™ (a patented, crystal clear and chemically resistant material); Thread Reducer: zinc-plated steel; Drain valve: brass; Magnet: strong neodymium rare earth magnet • Outdoor Compatibility: UV-resistant to protect against long-term sun exposure • Chemical Compatibility: Resistant to mineral and synthetic oils that are compatible with fluorocarbon elastomers (Viton™) and PMMA (acrylic) plastic • Includes: bowl, drain valve with magnet and thread reducer plate if required

THREADS	PART NUMBER	V
3/8" NPT	BOWL.038.MAG	1.0 fl.oz.
1/2" NPT	BOWL.050.MAG	1.0 fl.oz.
3/4" NPT	BOWL.075.MAG	1.0 fl.oz.
1" NPT	BOWL.100.MAG	1.0 fl.oz.
1-1/2" NPT	BOWL.150.MAG	1.0 fl.oz.

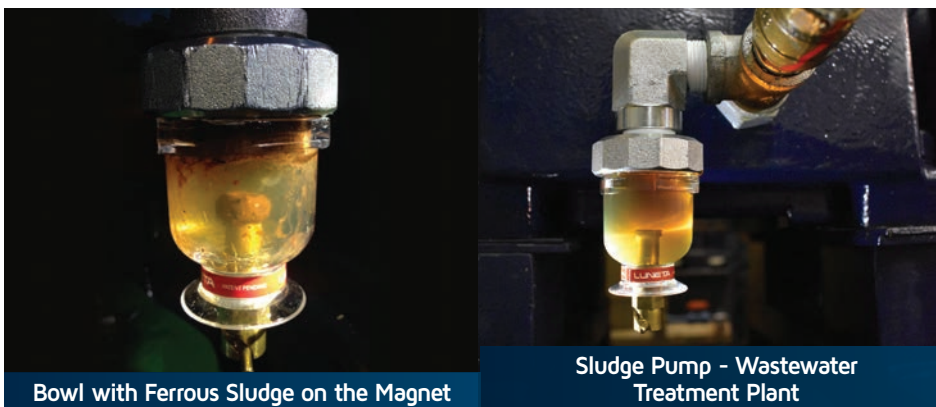

ACCESSORIES



Magnetic Drain Valve
DVALVE.MAG